

GAE08S12

DC-DC Converter Technical Manual V1.0

Date: 2012-02-25



| | | | | |
|---|--------------------------|------------------------|------------------------|---------------------------|
| Eighth-Brick DC-DC Converter | 36–75 V Input | 12 V Output | 8 A Current | Negative Logic |
|---|--------------------------|------------------------|------------------------|---------------------------|

Description

The GAE08S12 is an isolated DC-DC converter that uses an industry-standard eighth-brick structure, and features high efficiency and power density. It has the dimensions of 9.7 mm x 22.9 mm x 57.9 mm (0.38 in. x 0.90 in. x 2.28 in.) and provides the rated output voltage of 12 V and the maximum output current of 8 A.



Operational Features

- Input voltage: 36–75 V
- Output current: 0–8 A
- Low output ripple and noise
- Efficiency: 94.1% (12 V, 8 A)



GAE08S12

Mechanical Features

- Industry standard eighth-brick (H x W x D): 9.7 mm x 22.9 mm x 57.9 mm (0.38 in. x 0.90 in. x 2.28 in.)
- Weight: about 25 g

Control Features

- Remote on/off
- Remote sense
- Output voltage trim

Protection Features

- Input undervoltage protection
- Output overcurrent protection (hiccup mode)
- Output short circuit protection (hiccup mode)
- Output overvoltage protection (hiccup mode)
- Overtemperature protection (self-recovery)

Safety Features

- UL60950-1
- Underwriters Laboratory (UL) certification
- Class A requirements in EN55022 (after connecting to an external filtering circuit)
- UL94V-0
- Restriction of the use of certain hazardous substance (RoHS) 6

Mechanical Diagram

Unit of measurement: mm (in.)

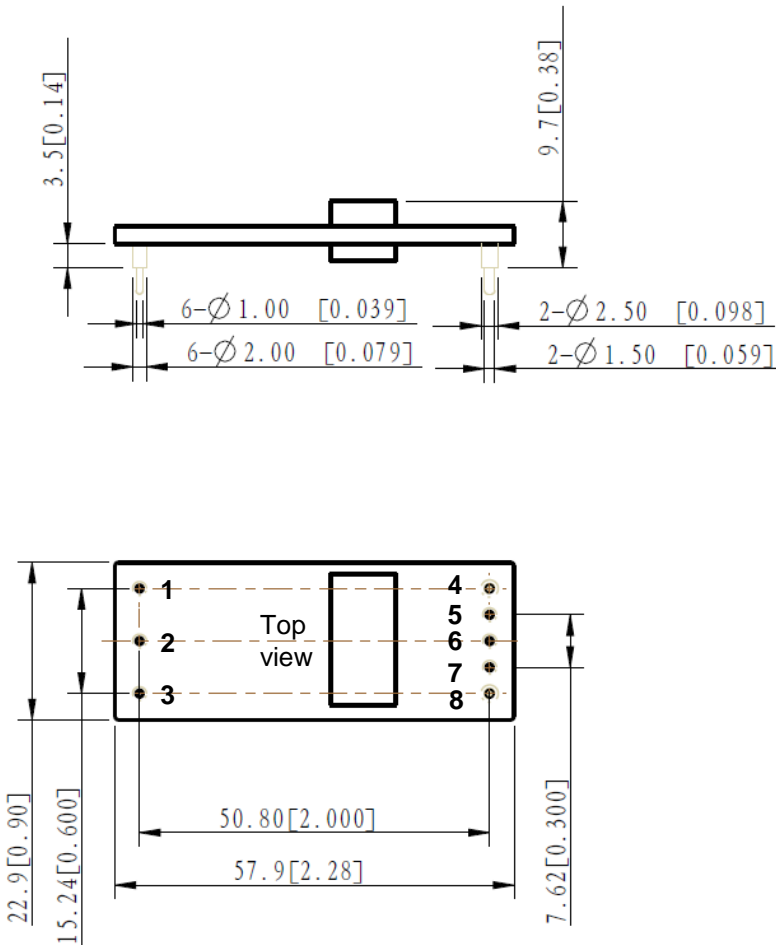

Pin description

| Pin No. | Function |
|---------|---------------|
| 1 | $V_{in} (+)$ |
| 2 | CNT |
| 3 | $V_{in} (-)$ |
| 4 | $V_{out} (+)$ |
| 5 | Sense (+) |
| 6 | Trim |
| 7 | Sense (-) |
| 8 | $V_{out} (-)$ |

Dimensions tolerance

| | |
|-----|---------------------------|
| .x | ± 0.2 mm (0.008 in.) |
| .xx | ± 0.13 mm (0.005 in.) |

Designation Explanation

G A E 08 S 12
 1 2 3 4 5 6

- 1 — Isolated
- 2 — Analog
- 3 — Eighth brick
- 4 — Output current: 8 A
- 5 — Single output
- 6 — Output voltage: 12 V

Electrical Specifications

Conditions: $T_A = 25^\circ\text{C}$ (77°F), Airflow = 1.0 m/s (200 LFM), $V_{in} = 48\text{ V}$, $V_{out} = 12\text{ V}$, unless otherwise specified.

| Parameter | Min. | Typ. | Max. | Units | Remarks |
|---------------------------------------|-------|------|-------|------------------|--|
| Absolute maximum ratings | | | | | |
| Input voltage | | | | | |
| Continuous | - | - | 80 | V | - |
| Transient (100 ms) | - | - | 100 | V | - |
| Operating ambient temperature | -40 | - | 85 | °C | See the thermal derating curve. |
| Storage temperature | -55 | - | 125 | °C | - |
| Operating humidity | - | - | 95 | % RH | Non-condensing |
| Input characteristics | | | | | |
| Operating input voltage | 36 | 48 | 75 | V | - |
| Maximum input current | - | - | 3.4 | A | $V_{in} = 0\text{--}75\text{ V}$; $I_{out} = 8\text{ A}$ |
| No-load loss | - | 2.4 | - | W | - |
| Input capacitance | 100 | - | - | μF | Electrolytic capacitor |
| Inrush transient | - | - | 1 | A ² s | - |
| Input reflected ripple current | - | - | 20 | mAp-p | - |
| Output characteristics | | | | | |
| Output voltage setpoint accuracy | 11.88 | 12.0 | 12.12 | V | $I_{out} = 4\text{ A}$ |
| Output power | 0 | - | 96 | W | - |
| Output line regulation | - | 0.2 | 1.0 | %Vo | - |
| Output load regulation | - | 0.5 | 1.0 | %Vo | - |
| Regulated voltage precision | - | - | 3 | %Vo | The whole range of V_{in} and I_{out} |
| Temperature coefficient | - | - | 0.02 | %Vo/°C | $T_A = -40^\circ\text{C}$ to $+85^\circ\text{C}$ (-40°F to $+185^\circ\text{F}$) |
| External capacitance | 220 | 470 | 5000 | μF | Electrolytic capacitor |
| Output current | 0 | - | 8 | A | - |
| Output ripple and noise | - | 50 | 200 | mVp-p | The whole range of V_{in} , I_{out} and T_A ; Oscilloscope bandwidth: 20 MHz |
| Output voltage adjustment range(trim) | 80 | - | 110 | %Vo | - |
| Out voltage overshoot | - | - | 5 | %Vo | The whole range of V_{in} , I_{out} and T_A |
| Output voltage rise time | - | 18.9 | 20 | ms | The whole range of V_{in} , I_{out} and T_A |
| Switching frequency | - | 260 | - | kHz | - |

Electrical Specifications

Conditions: $T_A = 25^\circ\text{C}$ (77°F), Airflow = 1.0 m/s (200 LFM), $V_{in} = 48\text{ V}$, $V_{out} = 12\text{ V}$, unless otherwise specified.

| Parameter | Min. | Typ. | Max. | Units | Remarks |
|------------------------------------|------|------|------|------------------|--|
| Protection Features | | | | | |
| Input undervoltage protection | | | | | |
| Startup threshold | 31 | 33.1 | 36 | V | - |
| Shutdown threshold | 30 | 31.3 | 35 | V | - |
| Hysteresis | 1 | - | 3 | V | - |
| Output overcurrent protection | 9 | - | 13.5 | A | $V_{in} = 38\text{--}75\text{ V}$; Hiccup mode |
| Output short circuit protection | - | - | - | - | Hiccup mode |
| Output overvoltage protection | 14.4 | 15 | 18 | V | Hiccup mode |
| Overtemperature protection | | | | | Self-recovery |
| Threshold | 105 | - | 125 | $^\circ\text{C}$ | The values are obtained by measuring the temperature of the PCB bottom near the thermal resistor. |
| Hysteresis | 5 | - | - | $^\circ\text{C}$ | |
| Dynamic Characteristics | | | | | |
| Overshoot amplitude | - | 224 | 600 | mV | $V_{in} = 38\text{--}75\text{ V}$; Current change rate: 0.1 A/ μs load : 25%–50%–25%, 50%–75%–50% Additional a 220 μF aluminum capacitor and a 1.0 μF ceramic capacitor across the load |
| Recovery time | - | 0 | 300 | μs | |
| Efficiency | | | | | |
| 100% load | 92 | 94.1 | - | % | $V_{in} = 48\text{ V}$; $I_{out} = 8\text{ A}$; $T_A = 25^\circ\text{C}$ (77°F) |
| 50% load | 91 | 93.1 | - | % | $V_{in} = 48\text{ V}$; $I_{out} = 4\text{ A}$; $T_A = 25^\circ\text{C}$ (77°F) |
| 20% load | - | 88.3 | - | % | $V_{in} = 48\text{ V}$; $I_{out} = 1.6\text{ A}$; $T_A = 25^\circ\text{C}$ (77°F) |
| Isolation characteristics | | | | | |
| Input-to-output Isolation voltage | - | 1500 | - | V DC | Basic Isolation |
| Other features | | | | | |
| Remote on/off voltage | | | | | |
| Low level | -0.7 | - | 1.2 | V | - |
| High level | 3.5 | - | 12 | V | - |
| On/Off current | | | | | |
| Low level | - | - | 1 | mA | - |
| High level | - | - | - | μA | - |
| Reliability characteristics | | | | | |
| Mean time between failures (MTBF) | - | 1.5 | - | Million hours | Airflow = 1.5 m/s (300 LFM); $T_A = 40^\circ\text{C}$ (104°F); 80% load; Telcordia SR332 Method 1 case 3 |

Qualification Testing

| Parameter | Units | Condition |
|--|-------|---|
| High Accelerated Life Test (HALT) | 4 | Lower operating limit: -60°C (-76°F); upper operating limit: 120°C (221°F); destruct limit: 40 G |
| Thermal Shock | 32 | 500 temperature cycles between -40°C (-40°F) and $+125^{\circ}\text{C}$ ($+257^{\circ}\text{F}$) with the temperature change rate of 20°C (68°F) per minute Lasting for 30 minutes both at -40°C (-40°F) and $+125^{\circ}\text{C}$ ($+257^{\circ}\text{F}$) |
| Temperature Humidity Bias | 16 | 85°C (185°F); 85% RH; no load; operating 1000 hours |
| High Temperature Operation Life (HTOL) | 16 | Rated input voltage; air flow: 2.0 m/s(400 LFM); ambient temperature: 50°C (122°F); operating 1000 hours under 50%–80% load |

Characteristic Curves

Figure 1: Efficiency
($T_A = 25^{\circ}\text{C}$ or 77°F)

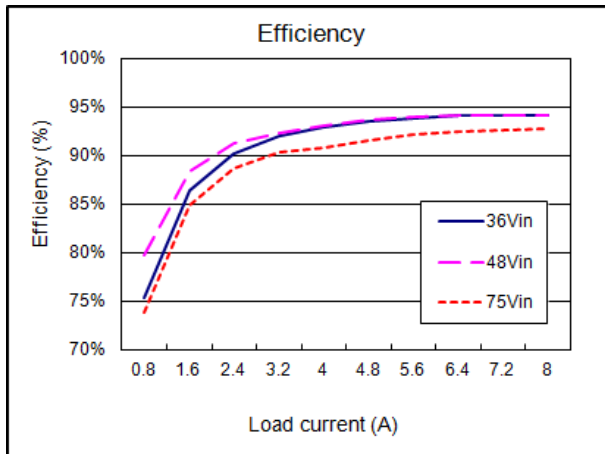

Figure 2: Power dissipation
($T_A = 25^{\circ}\text{C}$ or 77°F)

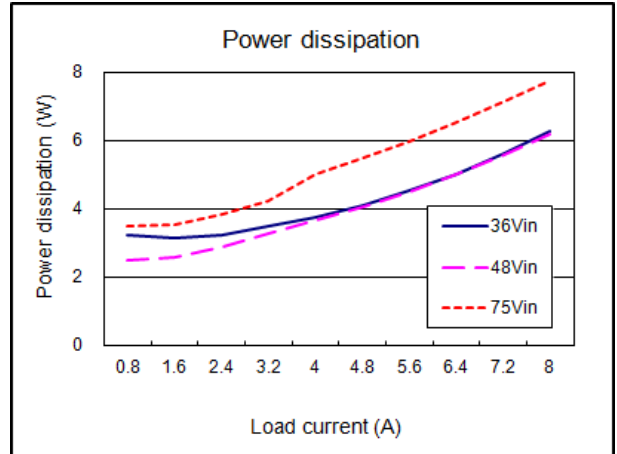

Figure 3: Thermal derating (Air is flowing from Vin to Vout; $V_{in} = 48\text{ V}$; $V_{out} = 12\text{ V}$)

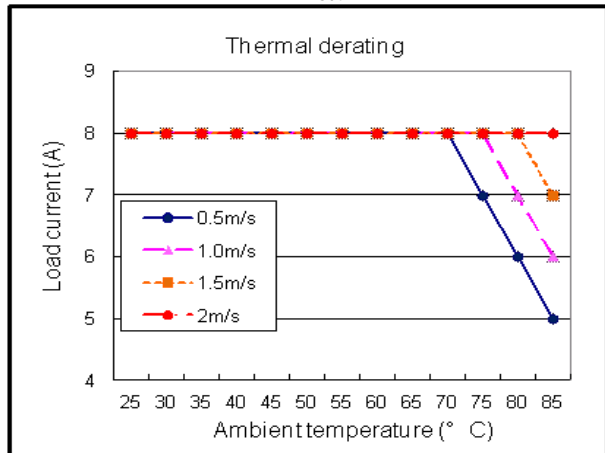

Figure 4: Thermal derating (Air is flowing from Vin(-) to Vin(+); $V_{in} = 48\text{ V}$; $V_{out} = 12\text{ V}$)

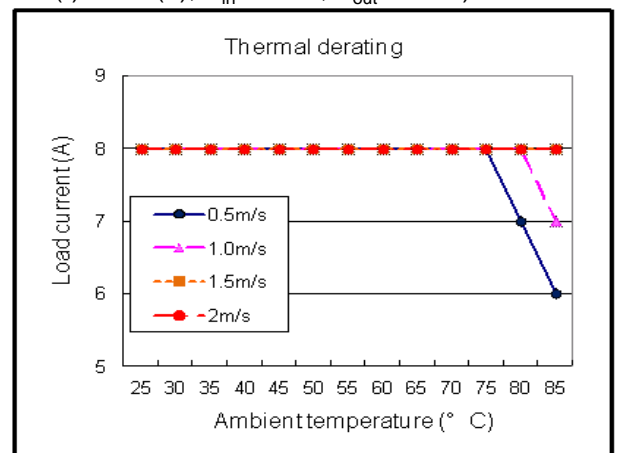

Figure 5: Thermal plot (Air is flowing from Vin to Vout; $T_A = 25^\circ\text{C}$ (77°F); Airflow = 1.5 m/s (300 FLM); Vin = 48 V; Vout = 12 V; Iout = 8 A)

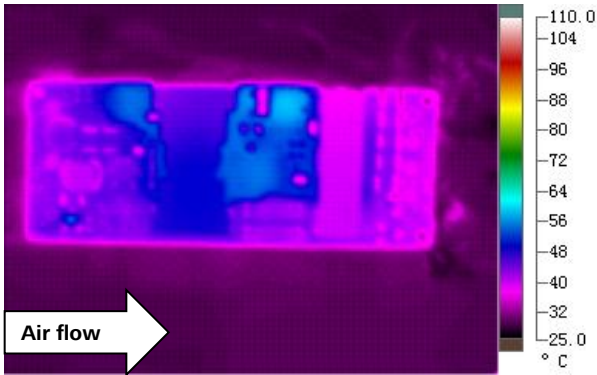
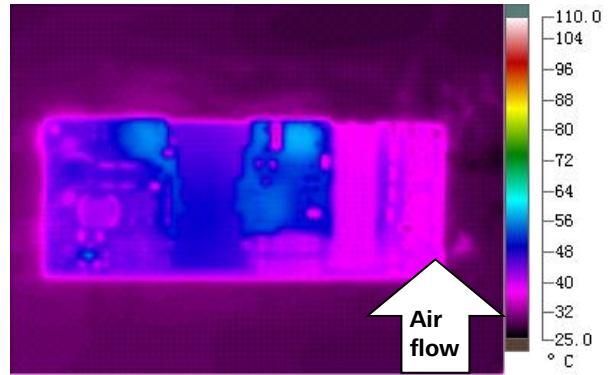

Figure 6: Thermal plot (Air is flowing from Vin(-) to Vin(+); $T_A = 25^\circ\text{C}$ (77°F); Airflow = 1.5 m/s (300 FLM); Vin = 48 V; Vout = 12 V; Iout = 8 A)



Typical Waveforms

Conditions: $T_A = 25^\circ\text{C}$ (77°F), Vin = 48 V.

Figure 7: Startup from CNT

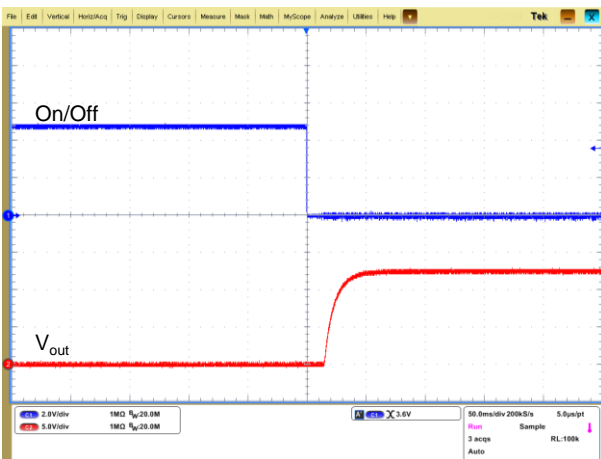

Figure 8: Shutdown from CNT

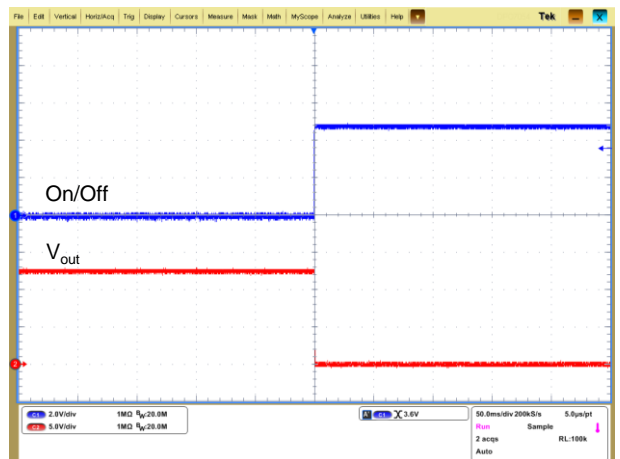

Figure 9: Startup from power on

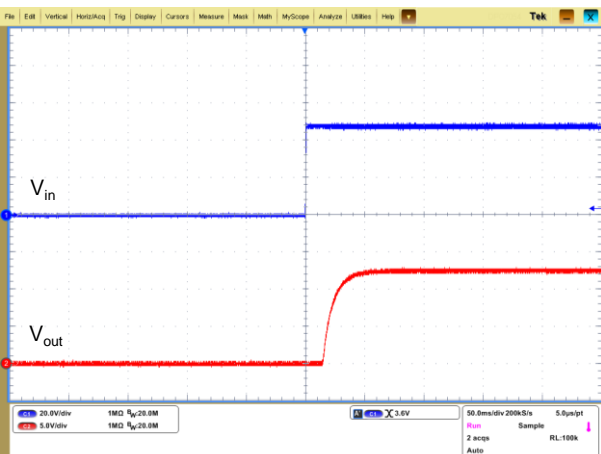

Figure 10: Shutdown from power off

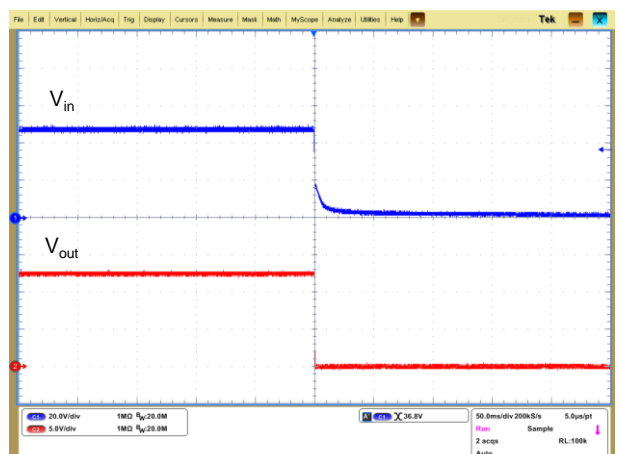

Figure 11: Output voltage response
(Load : 25%–50%–25%, $di/dt=0.1 \text{ A}/\mu\text{s}$)

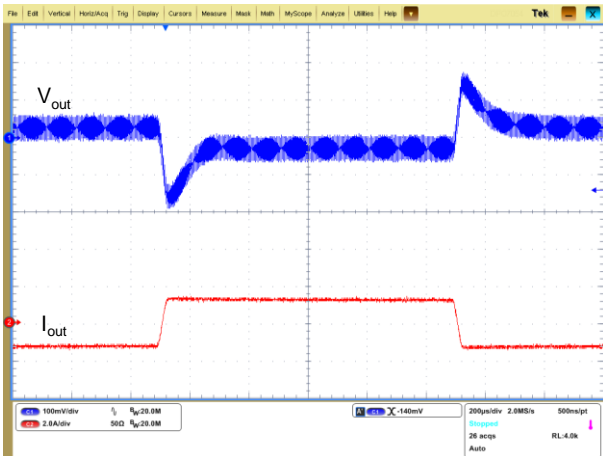

Figure 12: Output voltage response
(Load 50%–75%–50%, $di/dt=0.1 \text{ A}/\mu\text{s}$)

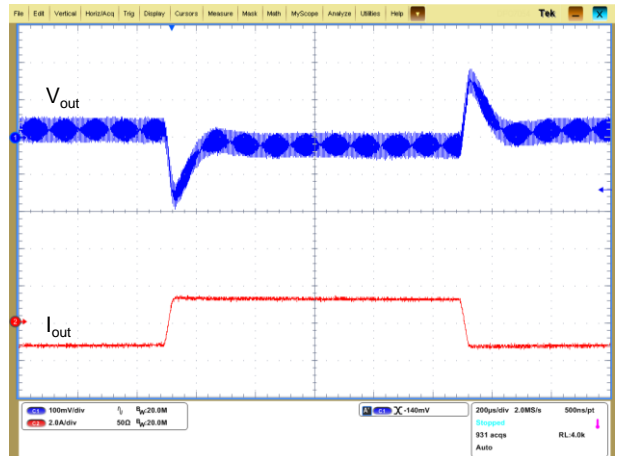
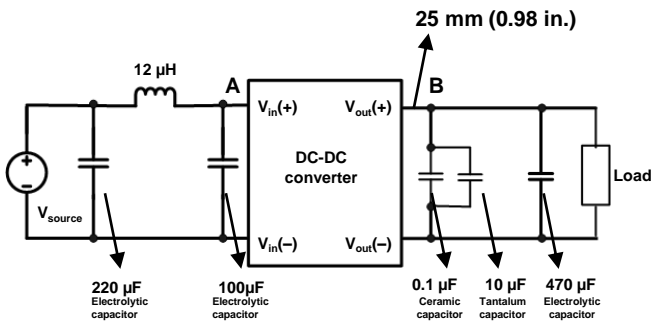

Figure 13: Test set-up diagram



NOTE

1. During the test of input reflected ripple current, the input terminal must be connected to a $12 \mu\text{H}$ inductor and a $220 \mu\text{F}$ electrolytic capacitor.
2. Point B, which is for testing the output voltage ripple, is 25 mm (0.98 in.) away from the $V_{\text{out}}(+)$ pin.

Conditions: $T_A = 25^\circ\text{C}$ (77°F), $V_{\text{in}} = 48 \text{ V}$, $V_{\text{out}} = 12 \text{ V}$, $I_{\text{out}} = 8 \text{ A}$.

Figure 14: Input reflected ripple current
(for point A in the test set-up diagram)

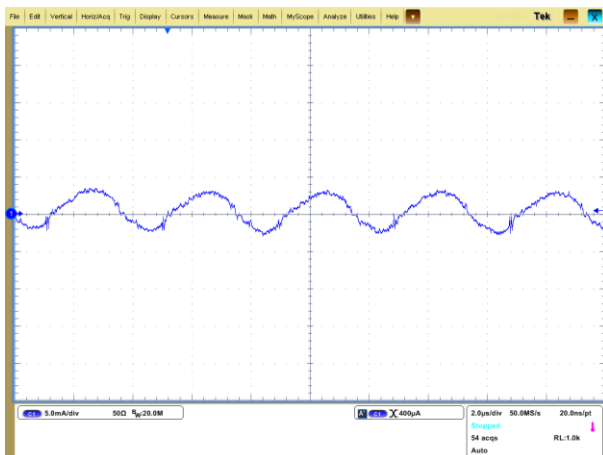
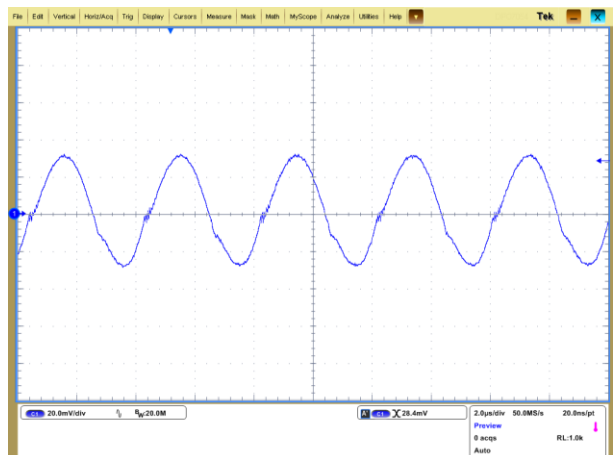

Figure 15: Output voltage ripple
(for point B in the test set-up diagram)



Feature Description

Remote On/Off

| Logic Enable | On/Off Pin Level | Status |
|----------------|-------------------------|-----------|
| Negative logic | Low level | Started |
| | High level or left open | Shut down |

The following are some circuits for driving the on/off pin.

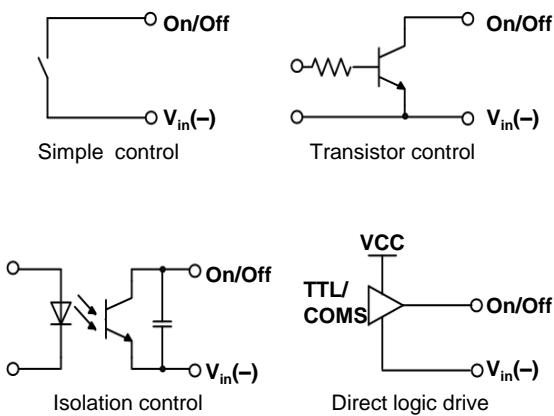

Remote Sense

This function is used to compensate for voltage drops on circuits.

The Sense(+), Sense(-), $V_{out}(+)$, and $V_{out}(-)$ terminals should meet the following requirements:

$$[V_{out}(+) - V_{out}(-)] - [\text{Sense}(+) - \text{Sense}(-)] \leq 10\% \times V_{nom} \quad (V_{nom} \text{ is the rated output voltage.})$$

If the remote sense function is disabled, the Sense(+) terminal connects to the $V_{out}(+)$ terminal and the Sense(-) terminal connects to the $V_{out}(-)$ terminal at the output end.

Figure 16: Configuration diagram for remote sense

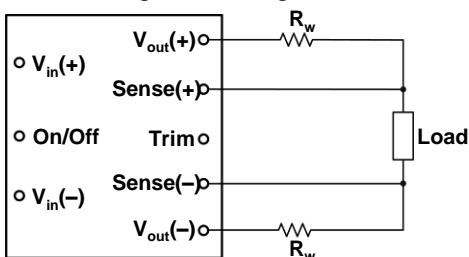

R_w indicates the line impedance between the output end and the load.

Output Voltage Trim

The output voltage can be adjusted within the range of 80% V_{nom} to 110% V_{nom} using a trim pin.

NOTE

If the trim pin is not used, it should be left open.

Trim Up

The output voltage can be increased by installing an external resistor between the trim pin and the Sense(+) terminal.

Figure 15: Configuration diagram for raising the output voltage

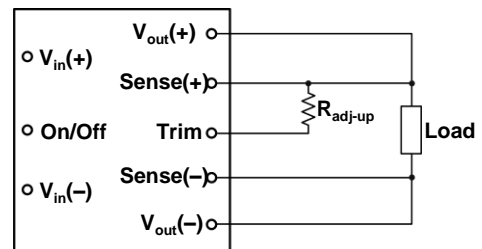

The following formula reflects the relationship between R_{adj-up} and V_{out} :

$$R_{adj-up} = \frac{5.1 \times V_{nom} \times (100 + \Delta)}{1.225 \times \Delta} - \frac{510}{\Delta} - 10.2(\text{kohm})$$

$$\text{Where, } \Delta = \frac{V_{out} - V_{nom}}{V_{nom}} \times 100$$

NOTE

Although the output voltage can be increased by both the remote sense and trim functions, the maximum increase in the output voltage is the larger value, rather than the sum of both values.

The GAE08S12 loading capability decreases as the voltage increases. Therefore, you need to ensure that the actual output power does not exceed the maximum output power when raising the voltage.

Trim Down

The output voltage can be decreased by installing an external resistor between the trim pin and the Sense(-) terminal.

Figure 16: Configuration diagram for lowering the output voltage

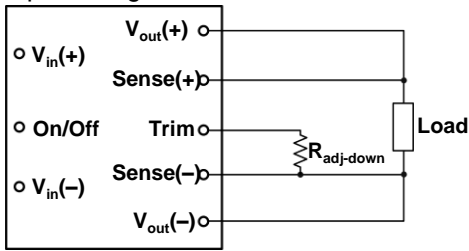

The following formula reflects the relationship between $R_{adj-down}$ and V_{out} :

$$R_{adj-down} = \frac{510}{\Delta} - 10.2(kohm)$$

$$\text{Where, } \Delta = \frac{V_{nom} - V_{out}}{V_{nom}} \times 100$$

Input Undervoltage Protection

The GAE08S12 is shut down after the input voltage drops below the undervoltage protection threshold for shutdown. The GAE08S12 starts to work again after the input voltage reaches the input undervoltage protection threshold for startup.

Output Overcurrent Protection

When the output current exceeds the overcurrent protection threshold, the GAE08S12 works in hiccup mode until overcurrent disappears. After the output current drops to the specified range, the GAE08S12 starts to work in normal mode.

Output Overvoltage Protection

When the output voltage exceeds the overvoltage protection threshold, the GAE08S12 works in hiccup mode.

Overtemperature Protection

The overtemperature function protects the GAE08S12 from being damaged at high temperatures. When the GAE08S12 temperature exceeds the overtemperature protection threshold, the output is disabled. After the GAE08S12 temperature drops below the threshold, the GAE08S12 starts to work again.

MTBF

The MTBF is calculated according to the Telcordia, SR332 Method 1 Case3. If the GAE08S12 is used at 40°C (104°F), the airflow over it can be increased to retain the MTBF.

Recommended Reverse Polarity Protection Circuit

Reverse polarity protection is recommended under installation and cabling conditions where reverse polarity across the input may occur.

Figure 17: Recommended reverse polarity protection circuits

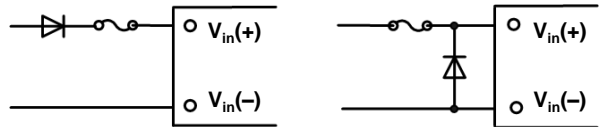

Recommended Fuse

The GAE08S12 has no internal fuse, but connects to an external fuse in actual use. To meet safety and regulatory requirements, a 5 A fuse is recommended.

NOTE

The fuse current should be 1.5 to 2 times the maximum operating current in actual use.

EMC

For the acceptance standard, see the *DC-DC Converter EMC Acceptance Manual*.

Figure 18: EMC test set-up diagram

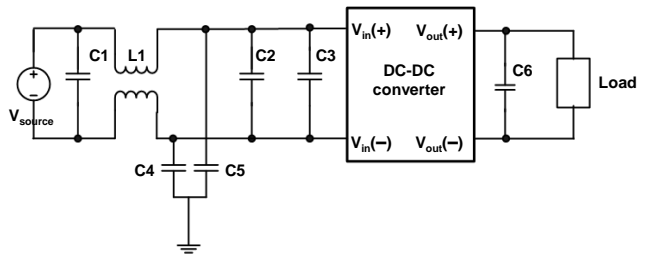

C1: Surface mount device (SMD) ceramic capacitor (100 V/1000 nF/X7R/1210)

C2: SMD ceramic capacitor (100 V/100 nF/±10%/X7R/1206)

L1: Common-mode inductor (single phase, 1320 μH/±25%/4 A/R5K/ 21 mm x 21 mm x 12.5 mm [0.83 in. x 0.83 in. x 0.49 in.]). The chip component with the same specifications can also be used.

C4: Plug-in film safety regulation capacitor (0.022 μF/250 V), meeting the 1 kV pressure resistance requirement.

C5: High-pressure resistant chip ceramic capacitor (22 nF/1000 V/X7R/1210). Chip ceramic capacitors are preferred.

C3: Electrolytic capacitor (100 μF/100 V)

C6: Electrolytic capacitor (470 μF)

Typical Application

Figure 19: Typical circuit applications

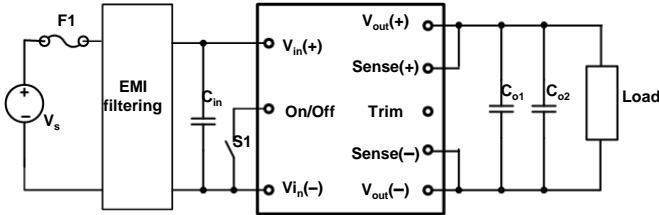

F1: 5 A fuse (fast blowing)

C_{in}: The high-frequency, low equivalent series resistance (ESR) electrolytic capacitor (100 μF/ 100 V) is recommended.

C_{o1}: The 1 μF ceramic capacitor is recommended.

C_{o2}: The 470 μF electrolytic capacitor is recommended.

NOTE

GAE08S12s cannot be connected in parallel.

Thermal Consideration

Sufficient airflow should be provided to help ensure reliable operating of the GAE08S12. Therefore, thermal components are mounted on the top surface of the GAE08S12 to dissipate heat to the surrounding environment by conduction, convection and radiation. Proper airflow can be verified by measuring the temperature at the PCB bottom near the thermal resistor.

Figure 20: Thermal test point

The PCB bottom near the thermal resistor



NOTE

The temperature at the thermal test point on the GAE08S12 cannot exceed 105°C (221°F). Otherwise, the GAE08S12 will be protected against overtemperature and will not operate properly.

Power Dissipation

The GAE08S12 power dissipation is calculated based on efficiency. The following formula reflects the relationship between the consumed power (P_d), efficiency (η), and output power (P_o):

$$P_d = P_o(1-\eta)/\eta$$

Mechanical Considerations

Installation

Although the GAE08S12 can be mounted in any direction, free airflow must be taken. Normally power components are always installed at the end of the airflow path or have separate airflow paths. The installation mode helps keep other system equipment cooler and increase component service life.

Soldering

The GAE08S12 is compatible with standard wave soldering techniques. During wave soldering, the setting parameters should base on the speciality of using flux, such as the preheating temperature and time, the soldering temperature and time and so on. To improve the soldering heighten, it is allowed to improve the preheating and soldering temperature, prolong the preheating and soldering time as the larger thermal capacity of the module. However, it is not allowed to exceed the high temperature limitation of the components that belong to the module.

When soldering the GAE08S12, ensure that the soldering iron is at 425°C (797°F) and contacts pins for a maximum of 3 seconds, because long-time soldering at high temperatures may cause the GAE08S12 interior to be damaged.

The GAE08S12 can be rinsed using the isopropyl alcohol (IPA) solvent or other proper solvents.